

## Resilient-Seated Gate Valves Outside Screw and Yoke

### IMPORTANT

Refer to Technical Data Sheet TFP2300 for warnings pertaining to regulatory and health information.

Scan the QR code or enter the URL in a web browser to access the most up-to-date electronic version of this document. Data rates may apply.



[docs.jci.com/tycofire/TFP1541](http://docs.jci.com/tycofire/TFP1541)

### General Description

TYCO Resilient-Seated Gate Valves are used in fire protection systems for on/off operation. The following end connection configurations are available:

- Flange x Flange
- Groove x Groove

All valves feature upstream and downstream tapped and plugged ports.

The ductile Iron body weighs approximately 50% less than conventional cast iron valves, which allows easier handling on site and reduced shipping costs.

The fully encapsulated EPDM ductile iron wedge ensures bubble-tight sealing.

Valve components are either inherently corrosion-resistant or protected with fusion-bonded epoxy resin coating for a long, dependable service life.

This valve is one of the lightest, most durable gate valves on the market today. Its design features and mate-

rial selection criteria fulfill the need for a dependable, long life and easy to operate gate valve.

### NOTICE

Never remove any piping component nor correct or modify any piping deficiencies without first de-pressurizing and draining the system. Failure to do so may result in serious personal injury, property damage, and/or impaired device performance.

It is the designer's responsibility to select products suitable for the intended service and to ensure that pressure ratings and performance data are not exceeded. Material and gasket selection should be verified for compatibility with the specific application. Always read and understand the installation instructions.

TYCO Gate Valves described herein must be installed and maintained in compliance with this document, in addition to the standards of any other authorities having jurisdiction. Failure to do so may result in serious personal injury or impair the performance of these devices.

The owner is responsible for maintaining their mechanical system and devices in proper operating condition. The installing contractor or device manufacturer should be contacted with any questions.

### Technical Data

#### Sizes

2 in. to 24 in. (DN50 to DN600)

#### Approvals

UL and ULC Listed  
FM Approved  
CE Certified  
EAC Approved

#### Maximum Working Pressure

- 2 in. to 12 in. (DN50 to DN300):  
300 psi (20,7 bar)
- 14 in. (DN350) and 16 in. (DN400):  
250 psi (17,2 bar)
- 18 in. to 24 in. (DN450 to DN600):  
200/250 psi (13.8/17,2 bar)

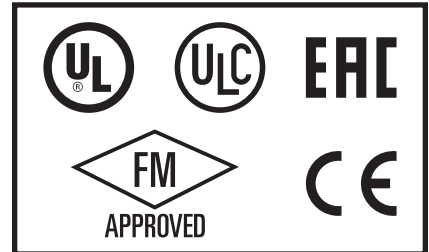

#### End Connections

Flange x Flange  
Groove x Groove

**Note:** For size applicability, see Table A.

#### Flanges

ASME B16.1/ASME B16.42  
EN 1092-2/ISO 7005-2  
Drilled to ANSI 150 or PN10/PN16 or AS 2129 (Table E)

#### Materials of Construction

See Figure 1

#### Threaded Ports

Two factory-plugged NPT threaded ports are located on the up- and downstream sides of the wedge for connection to valve trim.

#### Port NPT Inch Sizes

2 in. to 6 in. (DN50 to DN150) . . . . . 1/2  
8 in. (DN200) . . . . . 3/4  
10 in. to 24 in. (DN250 to DN600) . . . . . 1

### Installation

In piping systems, TYCO Resilient-Seated Gate Valves should be located where operation, inspection, and maintenance are readily accessible.

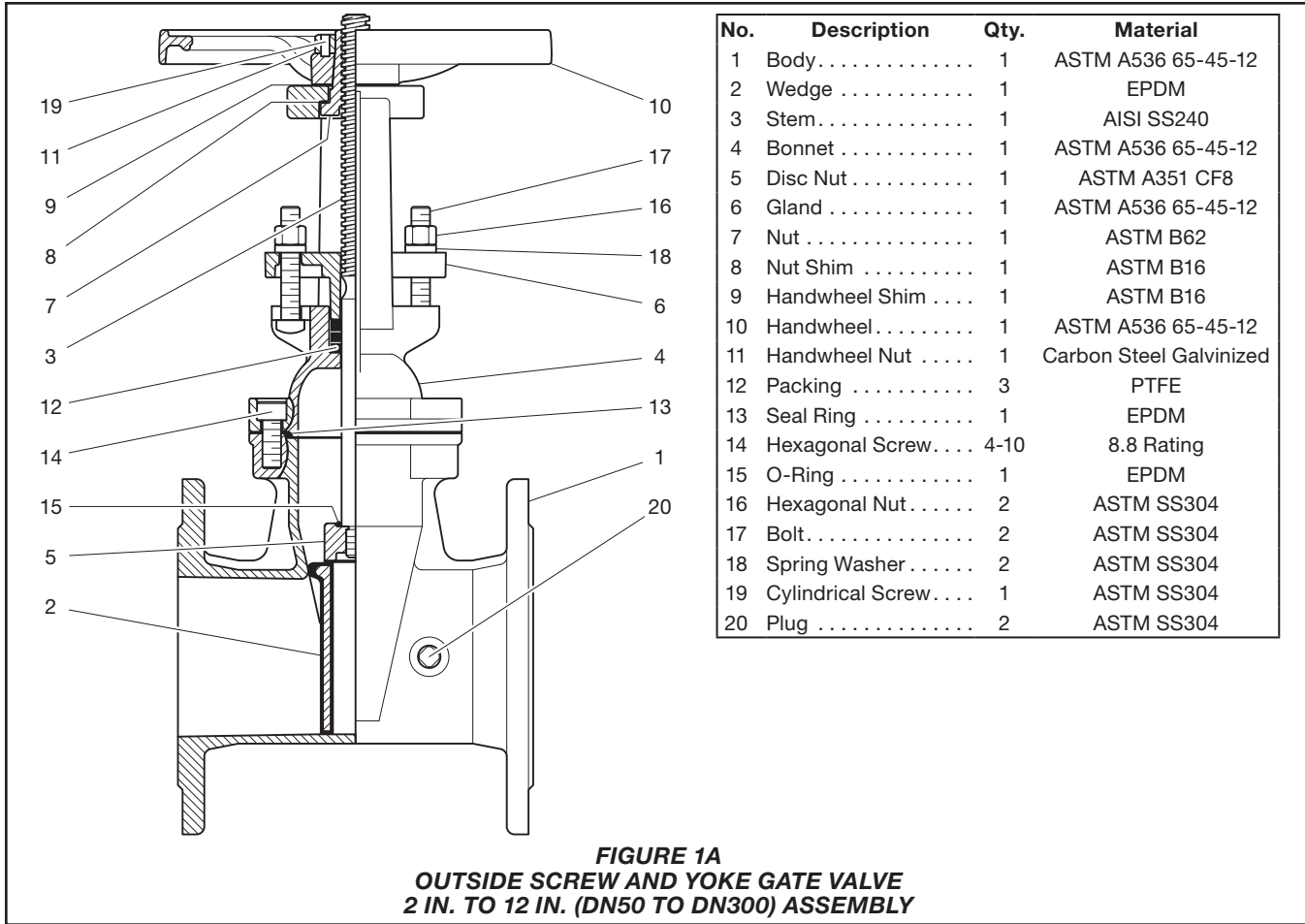

## Care and Maintenance

The TYCO Resilient-Seated Gate Valves must be maintained and serviced in accordance with this section.

Before closing a fire protection system main control valve for maintenance work on the fire protection system that it controls, obtain permission to shut down the affected fire protection system from the proper authorities and notify all personnel who may be affected by this decision.

After placing a fire protection system in service, notify the proper authorities and advise those responsible for monitoring proprietary and/or central station alarms.

The owner is responsible for the inspection, testing, and maintenance of their fire protection system and devices in compliance with this document, as well as with the applicable standards of the NFPA such as NFPA 25, in addition to the standards of any authority

having jurisdiction. The installing contractor or product manufacturer should be contacted relative to any questions. Any impairments must be immediately corrected.

Automatic sprinkler systems are recommended to be inspected, tested, and maintained by a qualified Inspection Service in accordance with local requirements and/or national codes.

For valve components referenced in this section, see Figures 1A and 1B.

Debris lodged in the sealing area of the wedge (2) may cause the valve to close hard. Backing off the handwheel (10) and closing it again, several times if necessary, can correct this problem.

The valve should never be forced to seat by applying a wrench or extension to the handwheel (10), as it may distort the valve components or score the sealing surfaces. All replacement parts must be obtained from the manufacturer to assure proper operation of the valve.

At initial valve installation the Hexagonal nuts (16) should be left only finger

tight to allow the packing (12) to remain in a relaxed state during normal valve operation.

After installation and before pressurizing the valve, inspect all pressure-bearing bolts and parts for adequate tightness to prevent leakage and ensure proper operation. Include the following parts, as shown in Figures 1A and 1B:

- Bonnet (4)
- Gland (6)
- Plugs (20)
- Upstream or downstream connections (20) and end connections
- Handwheel (10)

For applications where the valve is subject to vibration, a non-hardening thread sealant may be applied to the hexagonal nuts (16) to prevent self-loosening and subsequent disengagement of the packing (12).

If leakage past the O-ring (15) occurs, evenly tighten the hexagonal nuts (16) until the leakage ceases.

No.	Description	Qty.	Material
1	Body.....	1	ASTM A536 65-45-12
2	Wedge .....	1	EPDM
3	Stem.....	1	AISI SS420
4	Bonnet .....	1	ASTM A536 65-45-12
5	Disc Nut .....	1	ASTM A351 Cf8
6	Packing .....	3	PTFE
7	Packing Gland Bushing ..	1	ASTM 816
8	Packing Gland .....	1	ASTM A536 65-45-12
9	Nut .....	1	ASTM 862
10	Nut Shim .....	1	ASTM 816
11	Hand Wheel Shim .....	1	ASTM 816
12	Hand Wheel .....	1	ASTM A536 65-45-12
13	Hand Wheel Nut.....	1	Galvanized Carbon Steel
14	Plug .....	2	ASTM SS304
15	Taper Pin .....	1	ASTM SS316

No.	Description	Qty.	Material
16	O-Ring .....	1	EPDM
17	Seal Ring .....	1	EPDM
18	Hex Bolt .....	a	ASTM SS304 Class 8.8
19	Spring Washer .....	a	ASTM SS304
20	Hex Nut .....	a	ASTM SS304
21	Yoke .....	1	ASTM A536 65-45-12
22	Hex Bolt .....	2	ASTM SS304
23	Spring Washer .....	2	ASTM SS304
24	Hex Nut .....	2	ASTM SS304
25	Set Screw.....	1	ASTM SS304
26	Hex Bolt .....	4	ASTM SS304
27	Spring Washer .....	4	ASTM SS304
28	Hex Nut .....	4	ASTM SS304
29	Eyebolt .....	2	Galvanized Carbon Steel
30	Flat Washer .....	24	ASTM SS304

**Notes:**

- a. Qty for Item No. 18, 19, and 20 in accordance with valve size  
 Sizes 14 in. and 16 in. (DN350 and DN400) = Qty 12  
 Size 18 in. (DN450) = Qty 14  
 Sizes 20 in. and 24 in. (DN500 and DN600) = Qty. 16

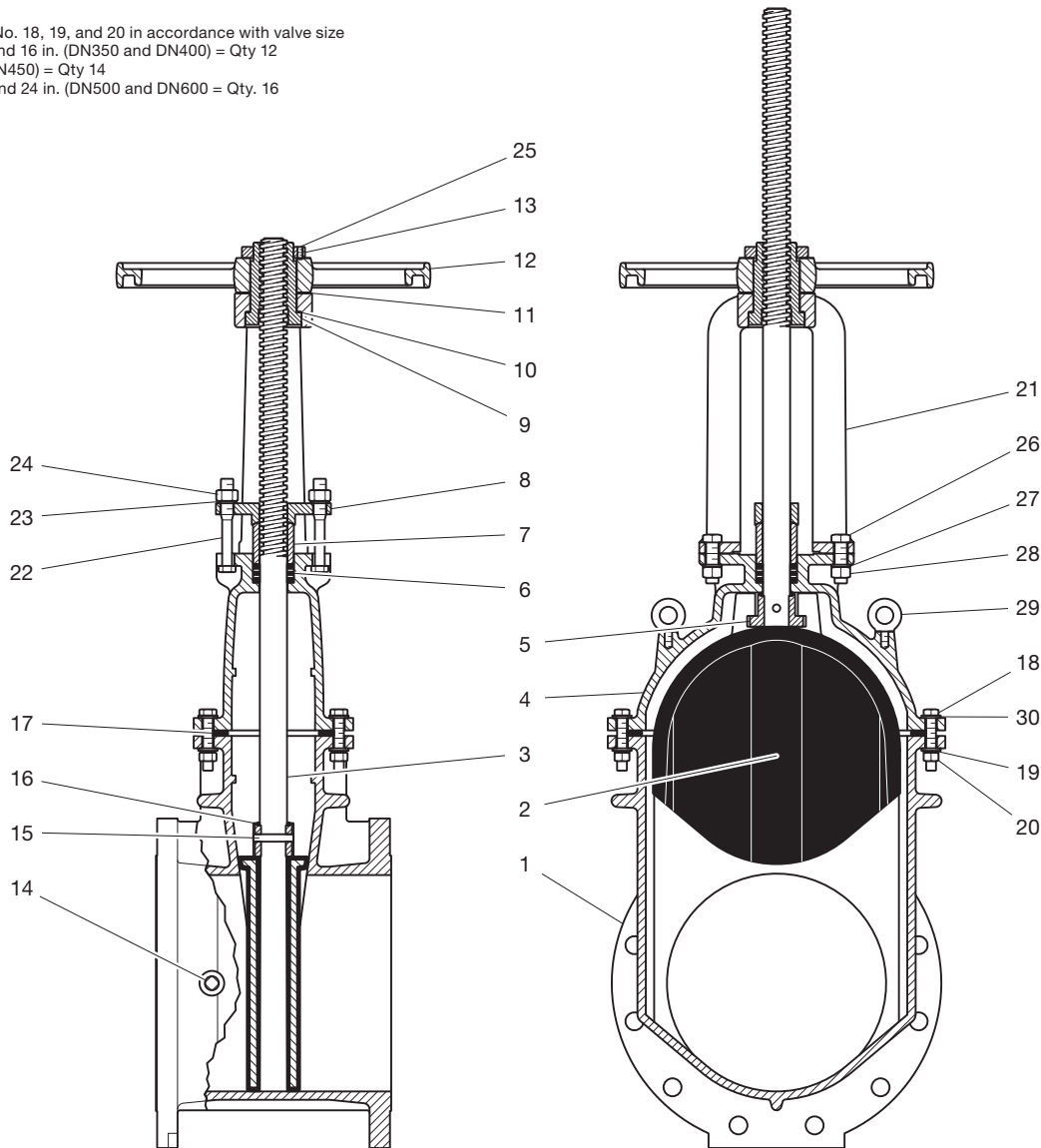

**FIGURE 1B**  
**OUTSIDE SCREW AND YOKE GATE VALVE**  
**14 IN. TO 24 IN. (DN350 TO DN600) ASSEMBLY**

Nominal Valve Size	Nominal Pipe Size	Nominal Dimensions in. (mm)			P Tapping Boss Size ANSI in. NPT	Nominal Handwheel Turns to Fully Operate (Open or Shut)	Approx. Weight F x F lb (kg)	Approx. Weight G x G lb (kg)
		L	CL1	CL2				
2 DN50	2.375 (60.3)	7.00 (178)	15.55 (395)	13.07 (332)	1/2	10	38.8 (17.64)	34.7 (15.8)
2 1/2 DN65	2.875 (73.0)	7.50 (190)	16.14 (410)	13.31 (338)		13	41.6 (18.91)	36.5 (16.6)
- DN65	3.000 (76.1)	7.50 (190)	16.14 (410)	13.31 (338)		13	41.6 (18.91)	36.5 (16.6)
3 DN80	3.500 (88.9)	8.00 (203)	18.9 (480)	14.96 (380)		16	48.7 (22.13)	48.0 (21.8)
4 DN100	4.500 (114.3)	9.00 (229)	22.56 (573)	17.72 (450)		20	59.8 (27.16)	52.8 (24.0)
- DN150	6.500 (165.1)	10.00 (254)	29.53 (750)	23.31 (592)		30	103.2 (46.9)	94.6 (43.0)
6 DN150	6.625 (168.3)	10.50 (267)	29.53 (750)	23.31 (592)		30	103.2 (46.9)	94.6 (43.0)
8 DN200	8.625 (219.1)	11.50 (292)	37.64 (956)	29.45 (748)	3/4	20	158.4 (72.0)	162.8 (74.0)
10 DN250	10.750 (273.1)	13.00 (330)	46.26 (1175)	34.96 (888)	1	25	244.2 (111.0)	233.2 (106.0)
12 DN300	12.750 (323.9)	14.00 (356)	51.89 (1318)	39.57 (1005)		30	367.4 (167.0)	352.0 (160.0)
14 DN350	14.014 (355.6)	15.00 (381)	62.09 (1577)	47.44 (1205)		29	511.5 (232.0)	-
16 DN400	16.000 (406.4)	15.98 (406)	70.87 (1800)	54.45 (1383)		33.5	714.3 (324)	-
18 DN450	24.02 (610)	17.01 (432)	61.97 (1574)	80.63 (2048)		37.5	1069.2 (485)	-
20 DN500	24.02 (610)	17.99 (457)	69.29 (1760)	90.43 (2297)		42	1406.5 (638)	-
24 DN600	30.00 (762)	20.00 (508)	77.87 (1978)	102.36 (2600)		50	1869.5 (848)	-

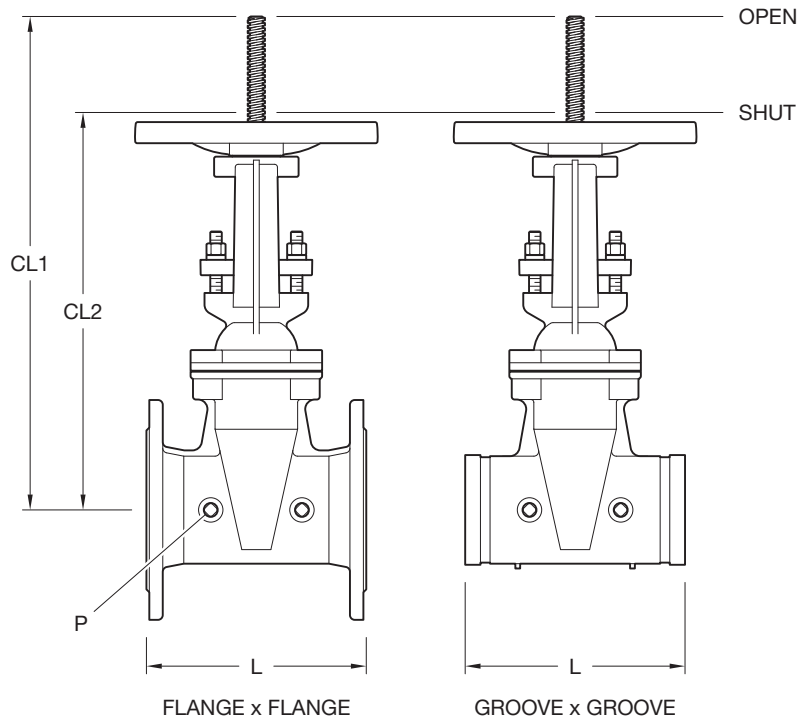

**FIGURE 2**  
**OUTSIDE SCREW AND YOKE GATE VALVE DN50 TO DN600**  
**NOMINAL DIMENSIONS**

Nominal Valve Size	Nominal Dimensions in In. (mm)								
	ANSI Class 150			ISO 7005-2 PN16			AS 2129 (Table E)		
	Dim. A	Dim. B	Qty. N	Dim. A	Dim. B	Qty. N	Dim. A	Dim. B	Qty. N
2 DN50	4.75 (120.5)	0.75 (19)	4	4.92 (125.0)	0.75 (19)	4	4.48 (114.0)	0.71 (18.0)	4
2 1/2 DN65	5.50 (139.5)	0.75 (19)	4	5.71 (145.0)	0.75 (19)	4	5.00 (127.0)	0.71 (18.0)	4
3 DN80	6.00 (152.5)	0.75 (19)	4	6.30 (160.0)	0.75 (19)	8	5.74 (146.0)	0.71 (18.0)	4
4 DN100	7.50 (190.5)	0.75 (19)	8	7.09 (180.0)	0.75 (19)	8	7.00 (178.0)	0.71 (18.0)	8
6 DN150	9.50 (241.5)	0.88 (22)	8	9.45 (240.0)	0.88 (23)	8	9.25 (235.0)	0.87 (22.0)	8
8 DN200	11.75 (298.5)	0.88 (22)	8	11.61 (295.0)	0.88 (23)	12	11.49 (292.0)	0.87 (22.0)	8
10 DN250	14.25 (362.0)	1.00 (25)	12	13.98 (355.0)	1.13 (28)	12	14.02 (356.0)	0.87 (22.0)	12
12 DN300	17.00 (432.0)	1.00 (25)	12	16.14 (410.0)	1.13 (28)	12	15.98 (406.0)	1.02 (26.0)	12
14 DN350	18.75 (476.3)	1.13 (28.6)	12	18.5 (470.0)	1.102 (28)	16	19.49 (495.0)	1.22 (31.0)	16
16 DN400	21.25 (539.8)	1.13 (28.6)	16	20.7 (525.0)	1.22 (31)	16	21.73 (552.0)	1.22 (31.0)	16
18 DN450	22.75 (577.9)	1.26 (32.0)	16	23.03 (585.0)	1.22 (31)	20	19.84 (504.0)	1.02 (26.0)	12
20 DN500	25.00 (635)	1.26 (32.0)	20	25.59 (650.0)	1.34 (34)	20	25.24 (641.0)	1.02 (26.0)	16
24 DN600	29.51 (749.5)	1.378 (35.0)	20	30.31 (770.0)	1.46 (37)	20	29.76 (756.0)	1.30 (33.0)	16

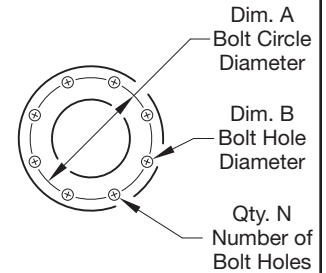

**NOTES**

- ANSI 150 and BS10 Table E flanges feature raised faces
- ANSI 125 and PN16 flanges feature flat faces
- (ANSI 125 listed only for differentiation from ANSI 150, Gate Valves featuring ANSI 125 flanges are not available)

**FIGURE 3  
GATE VALVE FLANGE  
NOMINAL DIMENSIONS**

SIZE KEY: B - 2-1/2 in. (DN65) D - 4 in. (DN100) F - 8 in. (DN200) H - 12 in. (DN300) K - 16 in. (DN400) M - 20 in. (DN500)  
A - 2 in. (DN50) C - 3 in. (DN80) E - 6 in. (DN150) G - 10 in. (DN250) J - 14 in. (DN350) L - 18 in. (DN450) N - 24 in. (DN600)

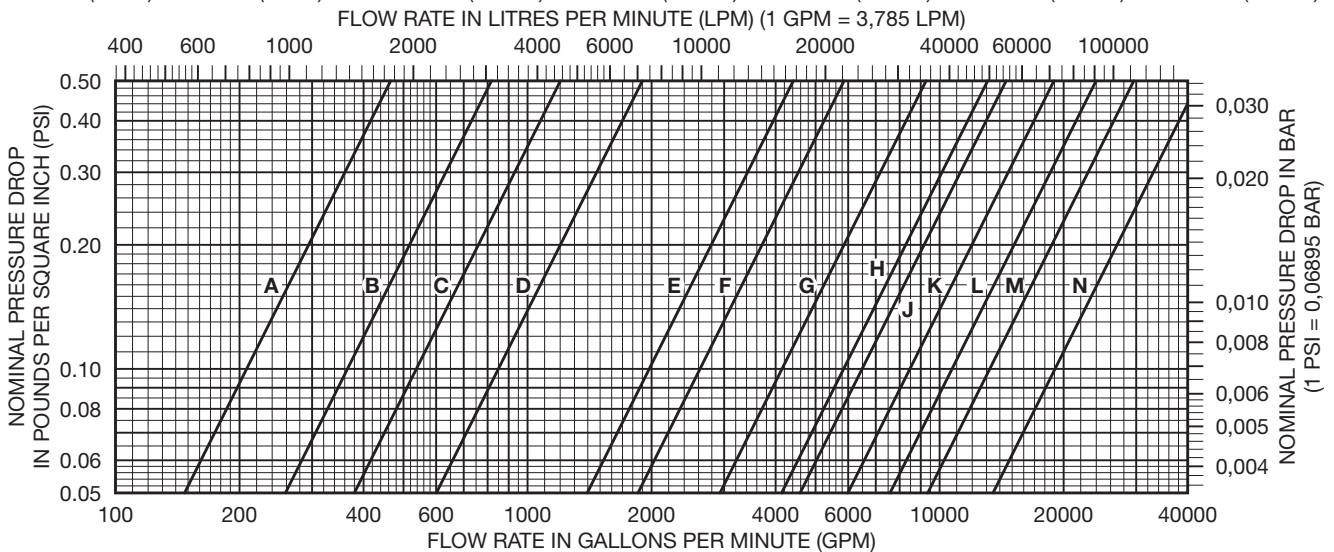

Nominal Valve Size	Nominal Pipe Size	Part Number			
		Flange x Flange ANSI Class 150	Flange x Flange ISO 7005-2 PN16	Flange x Flange AS 2129 (Table E)	Groove x Groove
2 DN50	2.375 (60.3)	TJRX0500003	TJRX0500001	TJRX0500005	TJRG0500604
2 1/2 DN65	2.875 (73.0)	TJRX0650003	TJRX0650001	TJRX0650005	TJRG0650734
– DN65	3.000 (76.1)	–	–	–	TJRG0650764
3 DN80	3.500 (88.9)	TJRX0800003	–	TJRX0800005	TJRG0800894
4 DN100	4.500 (114.3)	TJRX1000003	TJRX1000001	TJRX1000005	TJRG1001144
– DN150	6.500 (165.1)	–	–	–	TJRG1501654
6 DN150	6.625 (168.3)	TJRX1500003	TJRX1500001	TJRX1500005	TJRG1501684
8 DN200	8.625 (219.1)	TJRX2000003	TJRX2000001	TJRX2000005	TJRG2002194
10 DN250	10.750 (273.1)	TJRX2500003	TJRX2500001	TJRX2500005	TJRG2502734
12 DN300	12.750 (323.9)	TJRX3000003	TJRX3000001	TJRX3000005	TJRG3003244
14 DN350	14.0 (355.6)	TJRX3500003	TJRX3500001	TJRX3500005	–
16 DN400	16.0 (406.4)	TJRX4000003	TJRX4000001	TJRX4000005	–
18 DN450	24.02 (610)	TJRX4500003	TJRX4500001	–	–
20 DN500	24.02 (610)	TJRX5000003	TJRX5000001	–	–
24 DN600	30.00 (762)	TJRX6000003	TJRX6000001	–	–

**TABLE A**  
**OUTSIDE SCREW AND YOKE GATE VALVE**  
**PART NUMBERS**

## Limited Warranty

For warranty terms and conditions, visit [www.tyco-fire.com](http://www.tyco-fire.com).

## Ordering Procedure

Contact your local distributor for availability. When placing an order, indicate the full product name and Part Number (P/N). See Table A for a complete list of part numbers.