



MODELS **90G-21**
90A-21

Fire Protection Pressure Reducing Valves



MEA Approved

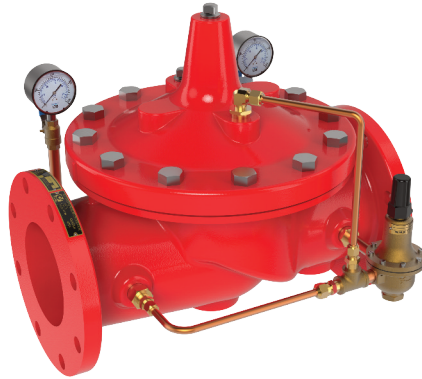

90-21 UL Listed Fire Protection Pressure Reducing Valve

- **UL Listed, ULC Listed, MEA Approved**
- **Globe or Angle Pattern**
- **Proven Reliable Design**
- **Available in Cast Bronze, Ductile Iron and Cast Steel**
- **Accurate Pressure Control**
- **In Line Service**
- **Grooved Ends (1-1/2" - 8")**

Cla-Val 90-21 Pressure Reducing Valves are indispensable in any fire protection system. Available in globe (90G-21) and angle patterns (90A-21), our diaphragm actuated design is proven to be highly reliable and easy to maintain. Globe and angle pattern valves feature a full range of adjustments. These valves are also available in a variety of material options. Epoxy coating is strongly recommended for all fire system valves (excluding bronze valves). All configurations of the valve can be supplied with optional internal and external epoxy coating of the main valve wetted surfaces.

Special System Water Control Valves – Class II
UL Product Category VLMT – File No. Ex 2534

Function

Cla-Val 90G-21 (globe) and 90A-21 (angle) Pressure Reducing Valves automatically reduce a higher inlet pressure to a steady lower outlet pressure regardless of changing flow rate and/or varying inlet pressure. The valves pilot control system is very sensitive to slight downstream pressure fluctuations, and will automatically open or close to maintain the desired pressure setting. The downstream pressure can be set over a wide range by turning the adjustment screw on the CRD pilot control. The adjustment screw is protected by a screw-on cover, which can be sealed to discourage tampering.

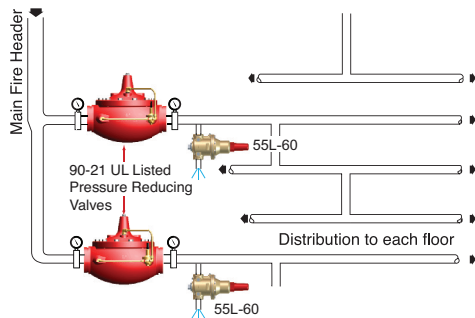

Schematic Diagram

- | Item | Description |
|------|--|
| 1 | 100KX Hytrol Main Valve |
| 2 | X58C Restriction Assembly |
| 3 | CRD Pressure Reducing Control (see note) |
| 4 | X46A Flow Clean Strainer |
| D | Check Valve Option |
| P | Gauge Option |

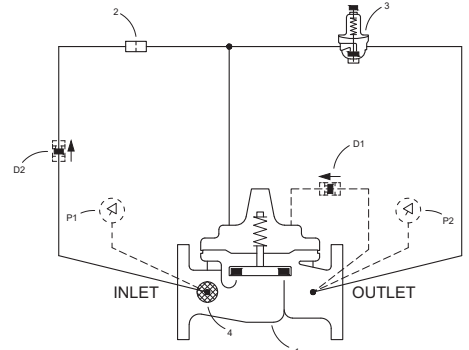

Note:

For Steel and Ductile Iron 300 Class Valves, use CRDKX with a special diaphragm washer, yoke and screws

Typical Application

Underwriters Laboratories requires the installation of pressure gauges upstream and downstream of the Pressure Reducing Valve.

A relief valve of not less than 1/2 inch in size must also be installed on the downstream side of the pressure control valve. Adequate drainage for the relief valve discharge must be provided.

The valve made be installed in either vertical or horizontal positions.

UL / ULC Listings

Size	Ductile Iron 150# Flanged	Ductile Iron 300# Screwed	Ductile Iron 300 # Flanged	Bronze 300# Threaded	Bronze 150# Flanged	Bronze 300# Flanged	Cast Steel 300# Flanged & Grooved End	Globe Pattern Ductile Iron Grooved End	Angle Pattern Ductile Iron Grooved End
1 1/2"	UL / ULC	UL / ULC	UL / ULC	UL / ULC			UL / ULC	UL / ULC	
2"	UL / ULC	UL / ULC	UL / ULC	UL / ULC	ULC	ULC	UL / ULC	UL / ULC	UL / ULC
2 1/2"	UL / ULC	UL / ULC	UL / ULC	UL / ULC	ULC	ULC	UL / ULC	UL	
3"	UL / ULC	UL / ULC	UL / ULC	UL / ULC	ULC	ULC	UL / ULC	UL / ULC	UL / ULC
4"	UL / ULC		UL / ULC		ULC	ULC	UL / ULC	UL / ULC	UL / ULC
6"	UL / ULC		UL / ULC				UL / ULC	UL / ULC	UL / ULC
8"	UL / ULC		UL / ULC					UL / ULC	
10"	UL / ULC		UL / ULC						
12"	UL / ULC		UL / ULC						

Dimensions

Valve Size (Inches)	1 1/2	2	2 1/2	3	4	6	8	10	12
A Threaded	7.25	9.38	11.00	12.50	—	—	—	—	—
AA 150 ANSI	8.50	9.38	11.00	12.00	15.00	20.00	25.38	29.75	34.00
AAA 300 ANSI	9.00	10.00	11.62	13.25	15.62	21.00	26.38	31.12	35.50
AAAA Grooved End	8.50	9.00	11.00	12.50	15.00	20.00	25.38	—	—
B	1.12	1.50	1.69	2.56	3.19	4.31	5.31	9.25	10.75
BB Grooved End	2.00	2.50	2.88	3.12	4.25	6.00	7.56	—	—
C Max.	5.50	6.50	7.56	8.19	10.62	13.38	16.00	17.12	20.88
CC Max. Grooved End	4.10	5.00	6.88	6.50	8.80	11.10	14.50	—	—
D	2.81	3.31	4.40	4.56	5.75	7.88	10.00	—	—
DD Grooved End	2.81	3.31	4.40	4.56	5.75	7.88	10.00	—	—
E Threaded	3.25	4.75	5.50	6.25	—	—	—	—	—
EE 150 ANSI	4.00	4.75	5.50	6.00	7.50	10.00	12.75	14.88	17.00
EEE 300 ANSI	4.25	5.00	5.88	6.38	7.88	10.50	13.25	15.56	17.75
EEEE Grooved End	—	4.75	—	6.00	7.50	10.00	—	—	—
F Threaded	1.88	3.25	4.00	4.50	—	—	—	—	—
FF 150 ANSI	4.00	3.25	4.00	4.00	5.00	6.00	8.00	8.62	13.75
FFF 300 ANSI	4.25	3.50	4.31	4.38	5.31	6.50	8.50	9.31	14.50
FFFF Grooved End	—	3.25	—	4.50	5.00	6.00	—	—	—
G (Max)	7.50	7.75	7.75	8.00	9.00	9.50	10.50	—	—
GG (Max)	8.10	8.00	—	8.13	9.31	10.50	11.50	—	—

Valve Size (mm)	40	50	65	80	100	150	200	250	300
A Threaded	184	238	279	318	—	—	—	—	—
AA 150 ANSI	216	238	279	305	381	508	645	756	864
AAA 300 ANSI	229	254	295	337	397	533	670	790	902
AAAA Grooved End	216	228	279	318	381	508	645	—	—
B	28	38	43	65	81	109	135	235	273
BB Grooved End	52	54	64	79	105	152	184	—	—
C Max.	140	161	192	208	270	340	406	435	530
CC Max. Grooved End	104	127	175	165	223	281	369	—	—
D	71	84	102	116	146	200	254	—	—
DD Grooved End	71	84	102	116	146	200	254	—	—
E Threaded	83	121	140	159	—	—	—	—	—
EE 150 ANSI	102	121	140	152	191	254	324	378	432
EEE 300 ANSI	108	127	149	162	200	267	349	395	451
EEEE Grooved End	—	121	—	152	191	254	—	—	—
F Threaded	48	83	102	114	—	—	—	—	—
FF 150 ANSI	102	83	102	102	127	152	203	219	349
FFF 300 ANSI	108	89	109	111	135	165	216	236	368
FFFF Grooved End	—	121	—	114	127	152	—	—	—
G (Max)	191	197	197	203	228	241	267	—	—
GG (Max)	206	203	—	207	236	267	292	—	—

Selection Guidelines

Flow Capacity Table

Flow Rate (GPM of Water)

Valve Size	Maximum	Minimum
1 1/2"	160	1
2"	262	1
2 1/2"	373	2
3"	576	2
4"	992	4
6"	2251	10
8"	3900	15
10"	6000	50
12"	8900	50

Optional UL Listed Materials for Seawater and Severe Service Applications:

- Nickel Aluminum Bronze (NAB) - ASTM B148 Alloy C95800
- Monel - QQ-N-288 Comp B - ASTM A494 Grade M30H
- Cast Steel - ASTM A216 Grade WCB
- 316 Stainless Steel - ASTM A743 Grades CF3M and CFM8
- Super Austenitic Stainless Steel - ASTM A351 Grade CK3MCuN (SMO 254)
- Super Duplex Stainless Steel - ASTM A890 Grade 5A (CE3MN)

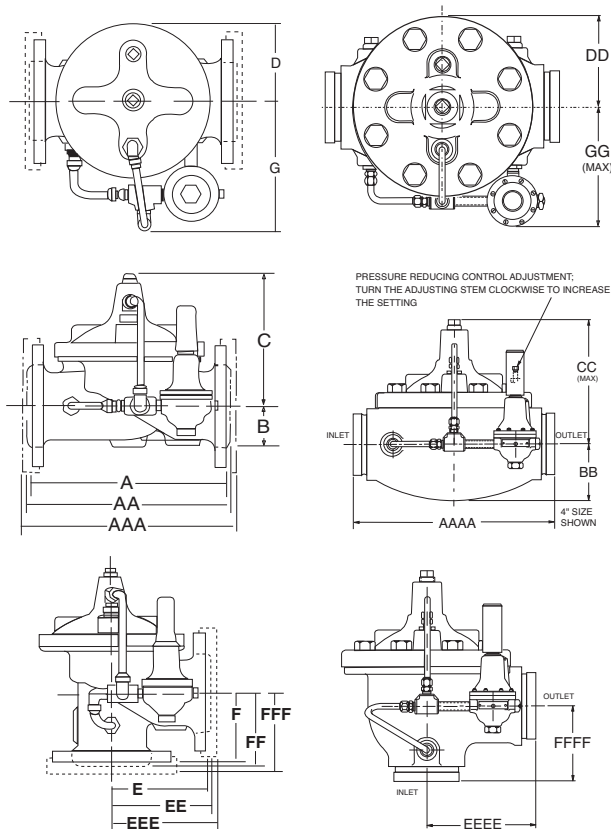

Sizes See chart on first page.

End Details 150 and 300 ANSI B16.42

Pressure Ratings Class 150 - 250 psi Max.
Class 300 - 300 psi Max

Water, to 180°F Max.

Standard Materials **Main Valve Body & Cover**
Ductile Iron ASTM A536 Grade 65-45-12

Standard Main Valve Trim:

Bronze Seat
Stainless Steel Stem

Standard Pilot Control System:

Cast Bronze with Stainless Steel Trim

Pressure Adjustment Ranges

Pressure Class	UL	ULC
1-1/2" - 8" 175 lb.	30-165	30-165
1-1/2" - 8" 300 lb.	30-165	30-165
10" - 12" 175 lb.	30-175	30-175
10" - 12" 300 lb.	30-175	30-175

Pressure Differential 10 PSI Minimum

Temperature Range Water to 180°F Maximum

Note: The Actual Capacity is limited by available DP.

SPECIAL NOTE: THE MODEL 90-21/90-21P CAN BE SUPPLIED WITH INTERNAL EPOXY COATING OF THE MAIN VALVE. THIS OPTION IS U.L. FILE NO. EX2855, C.C. NO. HNF3 EPOXY COATING IS STRONGLY RECOMMENDED FOR ALL CAST VALVES.



E-90-21 (R-02/2020)

CLA-VAL

1701 Placentia Avenue • Costa Mesa, CA 92627 • Phone: 949-722-4800
Fax: 949-548-5441 • Web Site: cla-val.com • E-mail: claval@cla-val.com

CLA-VAL CANADA

4687 Christie Drive
Beamsville, Ontario
Canada L0R 1B4
Phone: 905-563-4963
Fax: 905-563-4040
E-Mail: sales@cla-val.ca

CLA-VAL EUROPE

Chemin des Mésanges 1
CH-1032 Romanel/
Lausanne, Switzerland
Phone: 41-21-643-15-55
Fax: 41-21-643-15-50
E-Mail: cla-val@cla-val.ch

CLA-VAL UK

Dainton House, Goods Station Road
GB - Tunbridge Wells
Kent TN11 2 DH England
Phone: 44-1892-514-400
Fax: 44-1892-543-423
E-Mail: info@cla-val.co.uk

When Ordering, Specify:

- Model Number 90-21
- Size
- Globe or Angle Pattern
- Main Valve Body and Cover Material
- Threaded, Flanged or Grooved
- Pressure Class
- Optional Epoxy Coating (specify w/suffix KC)

© Copyright CLA-VAL 2020 Printed in USA Specifications subject to change without notice.