

# K-811-P

# Resilient Wedge Gate Valve

Non-Rising Stem: 4" - 12" / DN100 - DN300



International Data Sheet

## PRODUCT FEATURES

- Non-Rising Stem, Post Indicator Valve (PIV).
- Maximum Working Pressure 300 Psi / 20.7 Bar.
- Ductile Iron Body, Bonnet and Post Indicator Flange.
- Fusion Bonded Epoxy Coating cover all cast surfaces inside and out Meets requirements of AWWA / ANSI C550.
- Ductile Iron Wedge, symmetrical and fully encapsulated with molded EPDM rubber.
- Meets requirements of AWWA / ANSI C515 and is certified to ANSI / NSF 61 & 372.
- Four stem O-rings seal in lubricant –three above thrust collar, one below.
- Flange End drilling meets: ANSI B16.1, Class 125 and ANSI B16.42, Class 150. Mechanical Joint also available.
- Bi-directional flow.
- UL Listed and FM Approved.

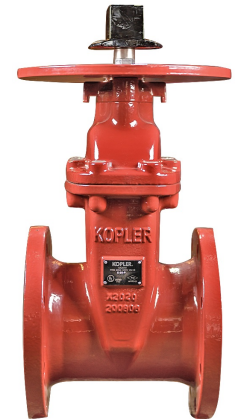

## MATERIAL SPECIFICATIONS

ID	PART NAME	MATERIAL
1	Body	Ductile Iron, ASTM A536 Grade 65-45-12
2	Wedge	Ductile Iron with EPDM Encapsulated
3	Wedge Nut	Bronze B148 C95200
4	Stem	Stainless Steel A276 Type 304
5	Gasket	Rubber D2000 EPDM
6	Bolt	Stainless Steel A276 Type 304
7	Bonnet	Ductile Iron, ASTM A536 Grade 65-45-12
8	O-ring	Rubber D2000 NBR
9	Thrust Collar	Bronze B148 C95200
10	O-ring	Rubber D2000 NBR
11	O-ring	Rubber D2000 NBR
12	Gland	Ductile Iron, ASTM A536 Grade 65-45-12
13	Dust Ring	Rubber D2000 NBR
14	Bolt	Stainless Steel A276 Type 304
15	Washer	Stainless Steel A276 Type 304
16	Washer	Stainless Steel A276 Type 304
17	Bolt	Stainless Steel A276 Type 304
18	Operating Nut	Ductile Iron, ASTM A536 Grade 65-45-12
19	Post Flange	Carbon Steel

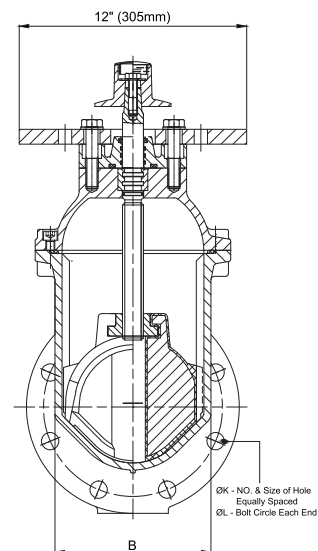
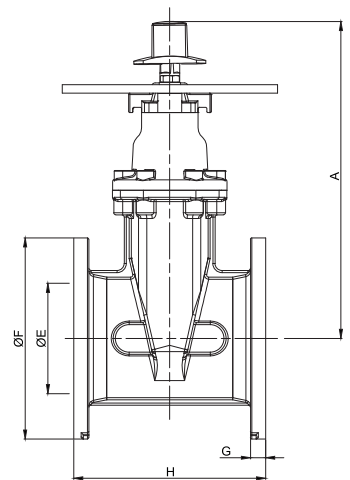
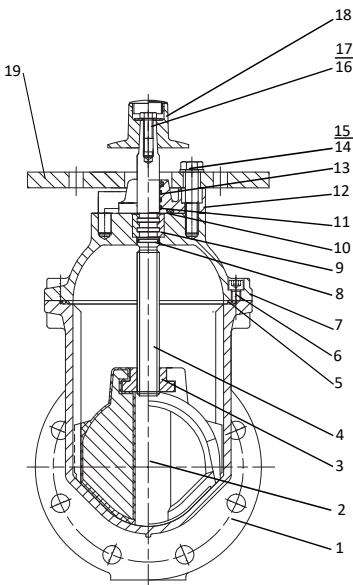

## DIMENSIONS

SIZE	A	B	ØE	ØF	G	H	NO.-ØK	ØL
4"	13.75 (350)	6.02 (153)	4.10 (103)	9.00 (229)	0.94 (23.9)	9.00 (229)	8- 0.75(19)	7.50 (190.5)
6"	18.30 (465)	8.19 (208)	6.10 (154)	11.00 (279)	1.00 (25.4)	10.50 (267)	8- 0.88(22)	9.50 (241.5)
8"	22.00 (559)	10.39 (264)	8.10 (205)	13.50 (343)	1.13 (28.6)	11.50 (292)	8- 0.88(22)	11.75 (298)
10"	25.00 (635)	12.80 (325)	10.03 (255)	16.00 (406)	1.19 (30.2)	13.00 (330)	12- 1.00(25)	14.25 (362)
12"	28.50 (724)	15.04 (382)	12.05 (306)	19.00 (483)	1.25 (31.8)	14.00 (356)	12- 1.00(25)	17.00 (432)

Dimensions: inch (mm).

## WEIGHT

Valve Size	4"	6"	8"	10"	12"
Weight lb. (kg)	66 (30)	110 (50)	165 (75)	242 (110)	361 (164)